



KLY-HK-BY05 Series Open Loop Hall Effect Current Sensor

KLY-HK-BY05系列开环型霍尔电流传感器



KLY-HK-BY05 series sensors are current sensors with Holzer effect and open loop principle. They are applied to measure DC, AC and pulse current under the condition of electric isolation.

KLY-HK-BY05系列传感器是应用霍尔效应开环原理的电流传感器，应用在电隔离条件下测量直流、交流、脉冲电流。

Products Features

Excellent accuracy High immunity to external interference
 Very good linearity Low temperature drift
 Optimized response time Wide frequency bandwidth
 No insertion losses

产品特点

精度高 抗干扰能力强
 良好的线性度 低温度漂移
 最佳的响应时间 频带宽
 无插入损耗

Instructions 使用说明

1. Incorrect wiring may cause the damage of sensor.
1. 保证接线正确，错误的接线可能会导致传感器损坏。
2. When the measured current through the center hole of the sensor, the current will be measured at the output end.
2. 当待测电流通过传感器的穿心孔，可在输出端测得电流大小。
3. The dynamic performance (di/dt and the response time) is the best when the primary hole is fully filled with the bus bar.
3. 母排完全充满初级穿孔时动态表现(Di/dt和响应时间)为最佳。
4. User can adjust the output extent of sensor if necessary.
4. 传感器输出幅度可根据用户需求进行适当的调节。
5. Rated input current and output voltage of sensor can be customized.
5. 可按用户需求定制不同额定输入电流和输出电压的传感器。

Electrical Data(Ta=25°C±5°C)电气参数

Parameters参数	Type型号	KLY-HK-BY05-0E1A						
	Rated input 额定测量电流 I_{FN}		±50A	±100A	±200A	±300A	±400A	±500A
Measure range 测量范围 I_r		±100A	±200A	±400A	±600A	±800A	±900A	±900A
Rated output voltage 额定输出电压 V_S		±4V(±1%)						
Supply voltage 电源电压 V_{CC}		±15V(±5%)						
Current consumption 功耗电流 I_c		<20mA						
Offset voltage 零点失调电压 V_o		<±25mV						
Offset voltage drift 失调电压温漂 V_{OT}	@ $I_p=0$, $T_A = -40^{\circ}C \sim +85^{\circ}C$	<±1 mV/°C						
Hysteresis offset voltage 磁失调电压 V_{OH}		<±25mV						
Linearity 线性度 ϵ_L		<1%FS						
Response time 响应时间 T_R	@ 50A/μS, 10% - 90%	<3 μS						
Galvanic isolation 绝缘电压 V_D	@ 50HZ, AC, 1min	3kV						
Frequency bandwidth 频带宽度	@ -3db	DC ~ 20K Hz						
Load resistance 负载电阻 R_M		≥10K Ω						
Operating temperature 环境温度 T_A		-40°C ~ +85°C						
Storage temperature 贮存环境温度 T_S		-40°C ~ +100°C						
Mass(approx) 毛重(约) m		135g						
Standards 执行标准		JB/T 7490-2007						

Mechanical Dimension(for Reference Only)结构参数

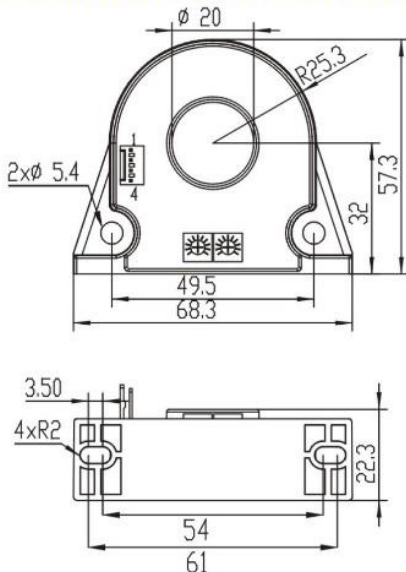

管脚定义 Pin Definition

1. + (Vcc)
2. - (Vss)
3. M (Vout)
4. G (GND)

Circuit Connection Diagram 电路连接示意图

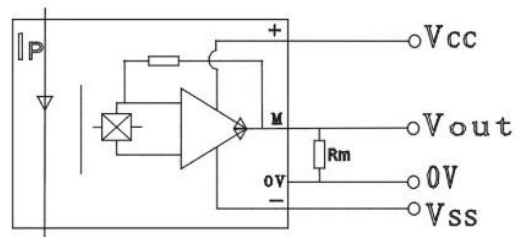

Casing material 外壳材料: 符合UL94-V0