



KLY-HT-BY09 Series Hall AC Current Transmitter

KLY-HT-BY09系列霍尔交流电流变送器



KLY-HT-BY09 Series current transmitter is an open loop device based on the measuring principle of the hall effect, with a galvanic isolation between primary and secondary circuit. It provides accurate electronic measurement of AC, pulsed currents.

KLY-HT-BY09系列传感器是应用霍尔效应开环原理的电流变送器，应用在电隔离条件下测量交流、脉冲电流。

Products Features

Excellent accuracy High immunity to external interference
 Very good linearity Low temperature drift
 Optimized response time No insertion losses

产品特点

精度高 抗干扰能力强
 良好的线性度 低温度漂移
 最佳的响应时间 无插入损耗

Instructions 使用说明

1. Incorrect wiring may cause the damage of sensor.
1. 保证接线正确，错误的接线可能会导致传感器损坏。
2. When the measured current through the center hole of the sensor, the current will be measured at the output end.
2. 当待测电流通过传感器的穿心孔，可在输出端测得电流大小。
3. The dynamic performance (di/dt and the response time) is the best when the primary hole is fully filled with the bus bar.
3. 母排完全充满初级穿孔时动态表现(Di/dt和响应时间)为最佳。
4. User can adjust the output extent of sensor if necessary.
4. 传感器输出幅度可根据用户需求进行适当的调节。
5. Rated input current and output voltage of sensor can be customized.
5. 可按用户需求定制不同额定输入电流和输出电压的传感器。

Electrical Data(Ta=25°C±5°C)电气参数

Parameters参数	Type型号	KLY-HT-BY09-0L1C						
		±50A	±100A	±200A	±400A	±600A	±800A	±1000A
Rated input 额定测量电流 I _{rn} @AC		±50A	±100A	±200A	±400A	±600A	±800A	±1000A
Measure range 测量范围 I _r @AC		±100A	±200A	±400A	±800A	±1200A	±1600A	±2000A
Rated output current 额定输出电流 I _s	DC	4-20mA(±1%)						
Supply voltage 电源电压 V _{cc}	DC	+24V(±5%)						
Current consumption 功耗电流 I _c		<35+I _{out} mA						
Zero current 零点电流 I ₀		<4±0.1mA						
Offset voltage drift 失调电压温漂 V _{or}	@ I _p =0 T _a = -40°C ~ +85°C	≤ ± 0.005 mA/°C						
Linearity 线性度 ε _L		<1%FS						
Response time 响应时间 T _r		≤200ms						
Galvanic isolation 绝缘电压 V _d	@ 50HZ, AC, 1min	3kV						
Frequency bandwidth 频带宽度	@ -3db	20~20k Hz						
Operating temperature 工作环境温度 T _A		-25°C ~ +85°C						
Storage temperature 贮存环境温度 T _S		-40°C ~ +100°C						
Mass(approx) 毛重 (约) m		335g						
Standards 执行标准		JB/T 7490-2007						

Mechanical Dimension(for Reference Only)结构参数

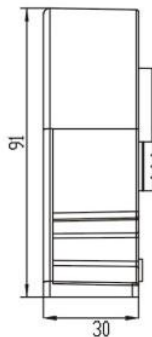
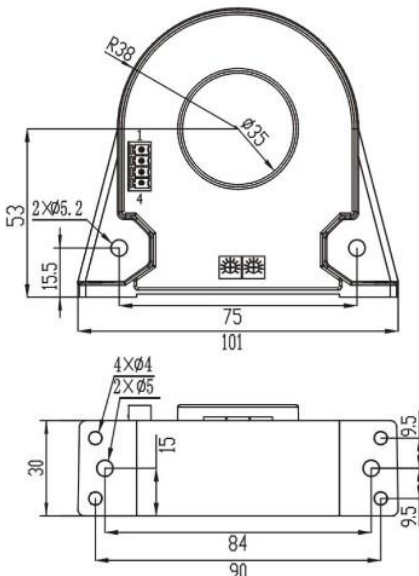

管脚定义 Pin Definition

1. + (Vcc)
2. G (GND)
3. M (Iout)
4. G (GND)

Circuit Connection Diagram 电路连接示意图

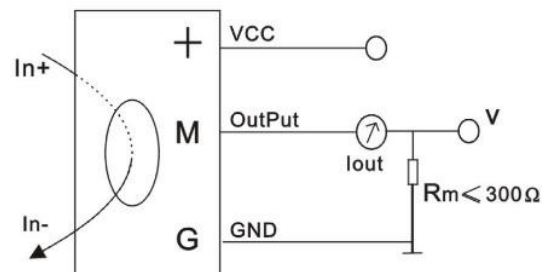

Casing material 外壳材料: 符合UL94-V0